

FITTING INSTRUCTION

Clamp mark in acc. with		Cables joining
ISO	PN	
1	L	Left directional lights
2	+	Rear fog lights
3	31	Ground
4	R	Right directional lights
5	58R	Right side parking lights
6	54	Stoplights
7	58L	Left side parking lights

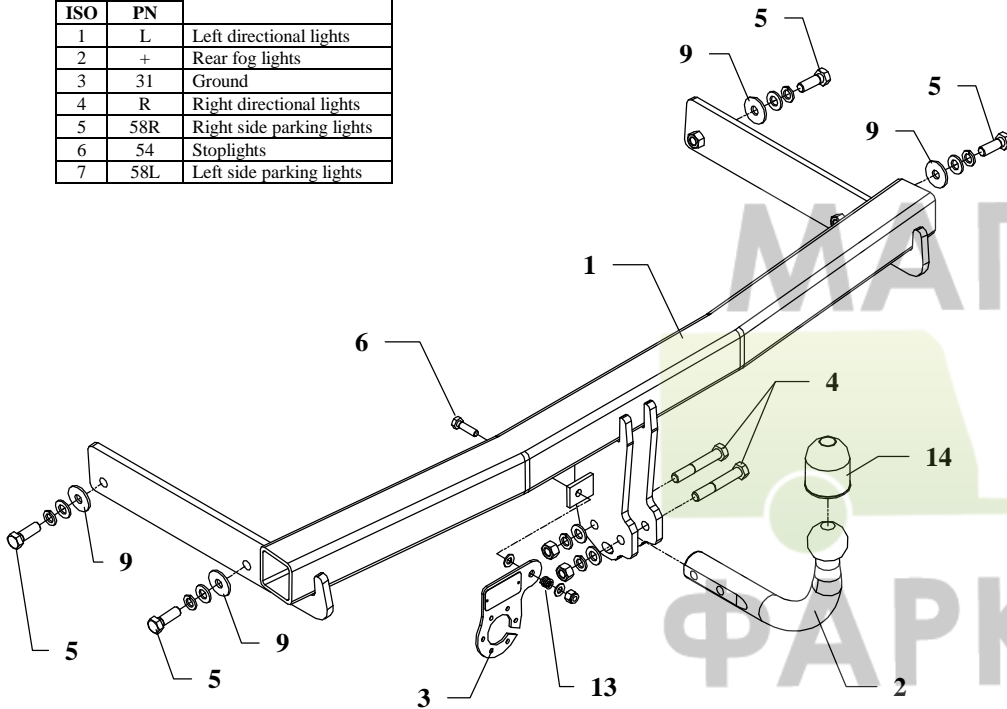

The instruction of the assembly

1. Disassemble the bumper, next twist off original reinforcement of the bumper (not used any more).
2. Put main bar of the towbar (pos. 1) inside chassis members and fix it using bolts M12x35mm (pos. 5) from accessories, use big washers $\varnothing 35 \times 12 \times 3$ mm (pos. 9).
3. Screw tight all bolts according to the torque shown in the table.
4. Fix tow-ball (pos. 2) and using bolts M12x70mm (pos. 5) from accessories.
5. Fix the socket plate (pos. 3) as shown on the drawing.
6. Tighten all bolts according to the torque shown in the table.
7. Connect electric wires of 7-poles socket according to the instruction of the car. (Recommend to make at authorized service station)
8. Complete paint layer damaged during installation.

Torque settings for nuts and bolts (8,8):

M 8 25 Nm
M 12 85 Nm

M 10 55 Nm
M 14 135 Nm

This towbar is designed to assembly in following cars: **VOLKSWAGEN PASSAT CL**, produced since 04.2005, catalogue number **K48** and is prepared to tow trailers max total weight **2000 kg** and max vertical load **85 kg**.

From manufacturer

Thank you for buying our product. Their reliability has been confirmed in many tests. Reliability of towbar depends also on correct assembly and correct exploitation. For this reasons we kindly ask to read carefully this instruction and apply to hints.

The towbar should be install in points described by a car producer.









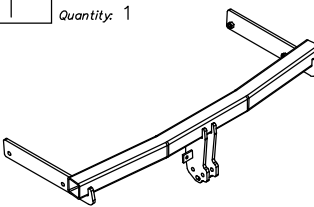

NOTE

After install the towbar you should get adequate note in registration book (at authorised service station). The car should be equipped with:

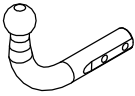
- Indicators
- Tow mirrors

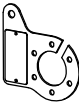
After 1000km check all bolts and nuts. The ball of towbar must be always kept clear and conserve with a grease.

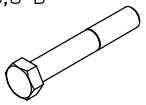
Towbar accessories:

Pos. 1 Name: Main bar Quantity: 1 	Pos. 5 Name: Bolt 8,8 B Quantity: 4 Dim.: M12x35mm 	Pos. 10 Name: Plain washer Quantity: 6 Dim.: Ø 13 mm 
	Pos. 6 Name: Bolt 8,8 B Quantity: 1 Dim.: M8x30mm 	Pos. 11 Name: Plain washer Quantity: 2 Dim.: Ø 8,5 mm 
Pos. 2 Name: Tow ball Quantity: 1 	Pos. 7 Name: Nut 8 B Quantity: 2 Dim.: M12 	Pos. 12 Name: Spring washer Quantity: 6 Dim.: Ø 12,2 mm 
Pos. 3 Name: Socket plate Quantity: 1 	Pos. 8 Name: Nut 8 B Quantity: 1 Dim.: M8 	Pos. 13 Name: Spring Quantity: 1 
Pos. 4 Name: Bolt 8,8 B Quantity: 2 Dim.: M12x70mm 	Pos. 9 Name: Washer Quantity: 4 Dim.: Ø35xØ12x3mm 	Pos. 14 Name: Ball cover Quantity: 1 



PPUH AUTO-HAK S.J.

Produkcja Haków Holowniczych
Henryk & Zbigniew Nejman
76-200 SŁUPSK ul. Słoneczna 16K
tel/fax (059) 8-414-414; 8-414-413
E-mail: office@autohak.com.pl
www.autohak.com.pl

Towing hitch (without electrical set)

Class: **A50-X** Cat. no. **K48**

Designed for:

Manufacturer: **VOLKSWAGEN**

Model: **PASSAT**

Type: **CL**

produced since 04.2005

Technical data:

D-value: 9,95 kN

maximum trailer weight: **2000 kg**

maximum vertical cup load: **85 kg**

Approval number acc. to regulations EKG/ONZ 55.01: **E20-55R-01 1816**

Foreword

This towbar is designed according to rules of safety traffic regulations. The towing hitch is a safety component and can be install only by qualified personnel. Any alteration or conversion of the towing hitch is prohibited and would lead to cancellation of design certification. Remove insulating compound and underseal from vehicle (if present) in the area of the matting surfaces of the towing hitch.

The vehicle manufacturer's specifications regarding trailer load and max. vertical cup load are decisive for driving, and values for the towing hitch cannot be exceeded.

D-value formula:

$$\frac{\text{Max trailer weight [kg]} \times \text{Max vehicle weight [kg]}}{\text{Max trailer weight [kg]} + \text{Max vehicle weight [kg]}} \times \frac{9,81}{1000} = D \text{ [kN]}$$